

Bulk Gas Purifiers

At ARM Purification we understand bulk gas delivery systems and design our purifiers to handle the volumes and purity specifications you desire, while designing our systems to be mechanically sound for minimal maintenance and to provide many years of service.

ARM Purification delivers a full range of point-of-use, frame-mounted and bulk purifier solutions for high and ultra high purity applications. Our proven purifiers have been trusted by the world's innovators to uphold the most stringent purity requirements for more than two decades.

Our Suite of Bulk Gas Purifiers

Advantage™ Bulk Series

Meet specific requirements with a modular, configurable design across three technologies:

- **APS60** - Getter Technology
- **APS70** - Heated Catalyst/Adsorber
- **APS80** - Reactive Catalyst
- **APS90** - Adsorber Technology

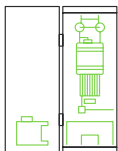

Point-of-Use

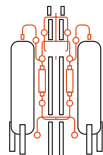

Frame-Mounted

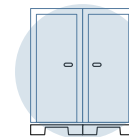

Bulk

At-a-Glance

FEATURES

- Flow rates of 10 to > 5000 Nm³/hr
- Powder coated steel enclosure
- 316L stainless steel construction
- Standard operating pressure of 250 PSIG
- Fully integrated PLC control
- Overpressure relief system
- Touchscreen HMI
- Ethernet connectivity

OPTIONS

- Flow metering
- Bypass valves
- Exterior enclosures
- UPS for control electronics

APPLICATIONS

- High production rate weld gas/purge gas
- Semiconductor process equipment; allowing for high fluctuations in flow demands
- Facility purifiers
- High pressure cylinder filling

Please contact factory for additional applications not listed.

APS60 - Getter Technology

These purifiers use getter material, typically at elevated temperatures, to remove impurities that react with the getter and chemically bond it. Once this chemical bond is made, it survives for the life of the purifier.

To achieve overall thermal efficiency, a gas-to-gas heat exchanger is incorporated to use the gas entering the getter vessel to cool the gas leaving the getter vessel. For added protection of downstream components, additional air or optional water cooling of the outlet gas stream are incorporated into the design.

Gases Purified	Impurities Removed to < 1 PPB
Rare Gases ¹	H ₂ O, O ₂ , CO, CO ₂ , H ₂ , N ₂ , THC
H ₂	H ₂ O, O ₂ , CO, CO ₂ , N ₂ , THC
N ₂ , N ₂ /Rare gas mix	H ₂ O, O ₂ , CO, CO ₂ , H ₂ , THC

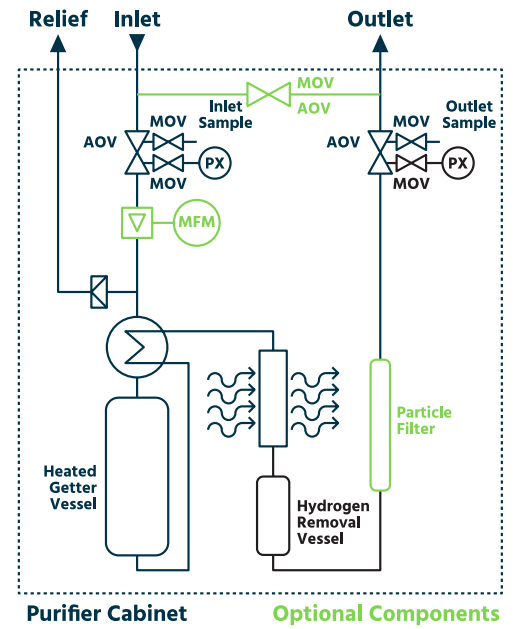

APS70 - Heated Catalyst/Adsorber

These purifiers use true catalytic materials that react with hydrocarbons and other impurities, converting them to gas molecules. These molecules are removed by a downstream adsorber stage, which is a parallel dual column arrangement allowing for regeneration without interruption of purified gas flow.

Gases Purified	Impurities Removed to < 1 PPB
O ₂ , CDA	H ₂ O, CO, CO ₂ , H ₂ , THC
Rare Gases ¹ , N ₂	H ₂ O, O ₂ , CO, CO ₂ , H ₂ , THC

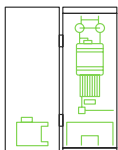
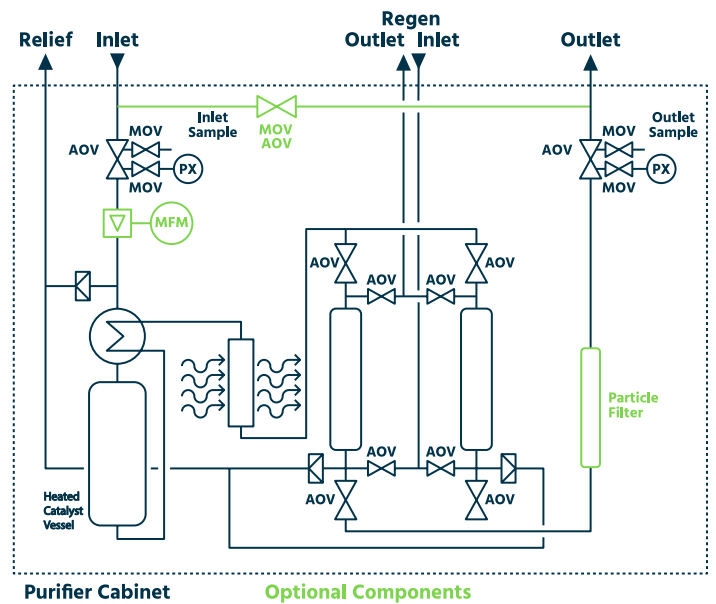

Point-of-Use

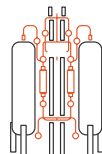

Frame-Mounted

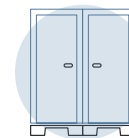

Bulk

APS80 - Reactive Catalyst

Purifiers use a reactive catalyst to remove impurities from a wide variety of gases.

The impurities are bonded with the reactive catalysts to form compounds on the surface of the material. To ensure uninterrupted purified gas flow, dual columns are arranged in parallel with the PLC control system performing the automatic switching and regeneration.

Gases Purified	Impurities Removed to < 1 PPB
Rare Gases ¹ , N ₂	H ₂ O, O ₂ , CO, CO ₂ , H ₂ , NMHC
H ₂	H ₂ O, O ₂ , CO, CO ₂ , NMHC

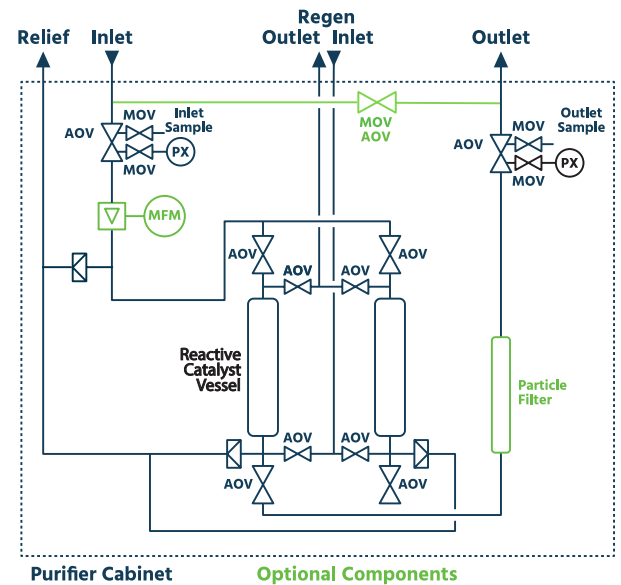

APS90 - Adsorber Technology

Purifiers use adsorber material to remove impurities from a wide variety of gases.

The impurities are adsorbed by the material. To ensure uninterrupted purified gas flow, dual columns are arranged in parallel with the PLC control system performing the automatic switching and regeneration.

Gases Purified	Impurities Removed to < 1 PPB
Rare Gases ¹ , H ₂ , N ₂ , O ₂ , CDA, XCDA, CO ₂	H ₂ O

¹ Rare Gases: Ar, He, Ne, Kr, Xe

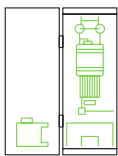
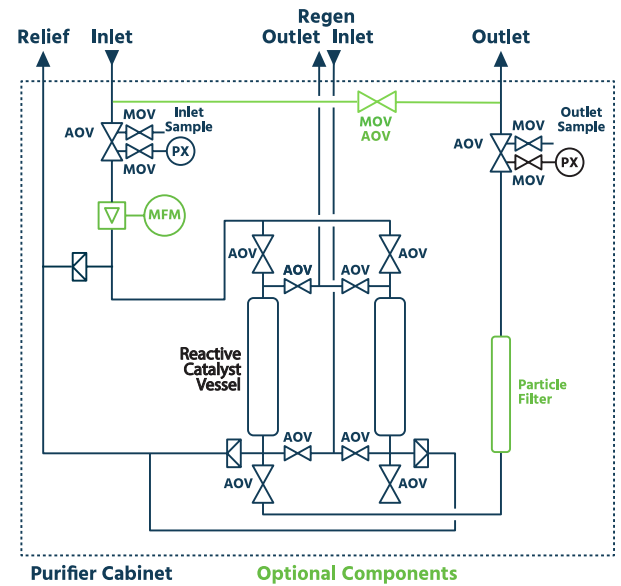

Point-of-Use

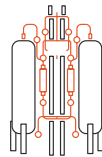

Frame-Mounted

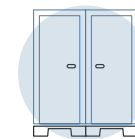

Bulk

Contact ARM Purification, or your local representative for assistance, or for gases and options not listed.

For more information on how we can meet your gas purification needs, visit www.armpurification.com.